

H I G H - P R E C I S I O N F A C E - A D J U S T A B L E I D - C H U C K U N I T

Our high-precision face-adjustable ID-Chuck Unit is a perfect fit to Portable Line Boring Machines of our „TBM-Series“ and provides ultra-high-precision set-up and aligning possibilities, especially when machining valves or other “work pieces” with limited access. Also available for your existing Line-Boring-Machine (other brands)!

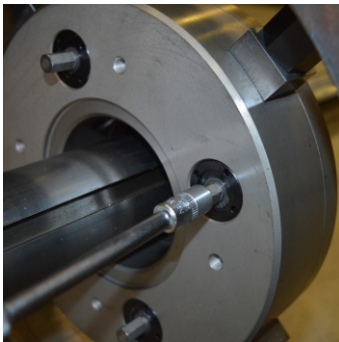

Alignment is also possible from the backside of the chuck.

Even the bearing unit is adaptable from both sides of the chuck for a maximum of flexibility!



All housing components are made of nitrogen hardened, high-strength steel to guarantee a long lasting, reliable life on-site. Friction surfaces are ground to tolerance since we want to provide a product, which delivers high accuracy and repeatability.

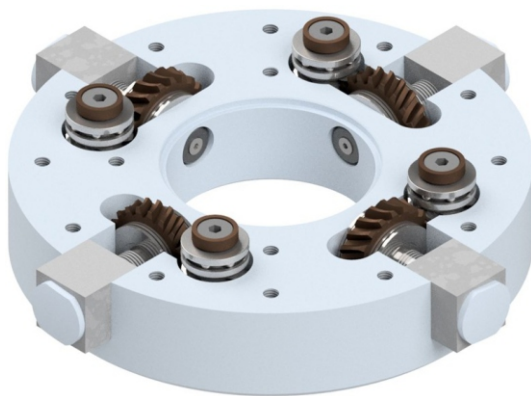

THE „INTERNAL“

4 sets of high-precision worm gear assemblies transmit the rotational movement of each aligning shafts to an axial movement of the clamping legs. Worms are hardened and ground, worm gears are made of a special high-strength bronze. Ball bearings guide all rotating parts to provide wear-out free operation. Worm bearings are pre-loaded and adjustable. The arrangement is maintenance-free!

1 alignment shaft rotation provides an axial leg movement of approx. 0.43 mm (0.017”). This relationship makes it easy to align in super high accuracies and tolerances!

TECHNICAL DETAILS & INFORMATION

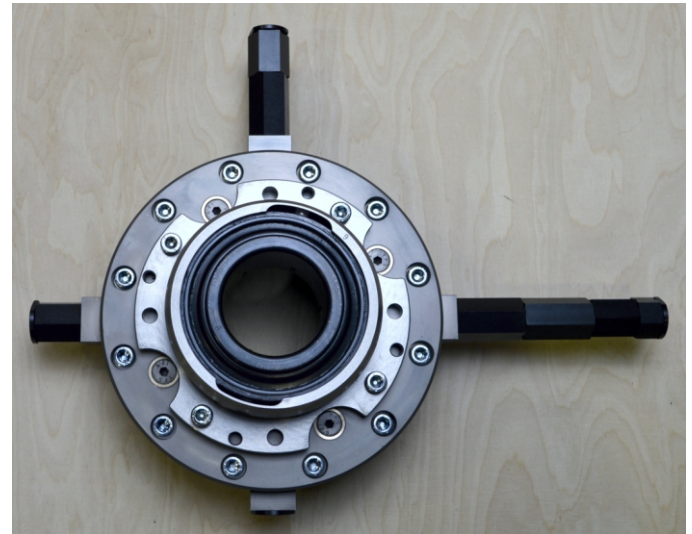
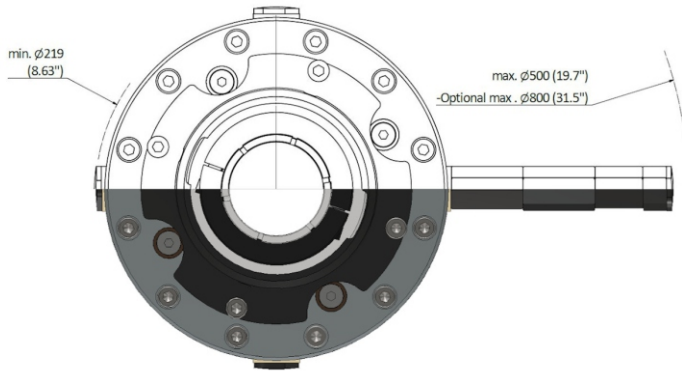

Clamping range of the standard configuration is $\text{Ø}219\text{-}500\text{ mm}$ (8.63-19.7"). An extension leg-set is available as an option and provides a clamping range up to $\text{Ø}800\text{ mm}$ (31.5").

STANDARD-SCOPE OF SUPPLY

Our ID-Chuck Unit comes with a complete set of adapter legs and spherical brackets for covering the clamping range $\text{Ø}219\text{-}500\text{ mm}$ (8.63-19.7"). Of course the spherical bearing is also included in the scope of supply.

For safe transportation and storage, we deliver the whole set in a durable carrying case with fitted foam-inlet.

Complete set ready to use!

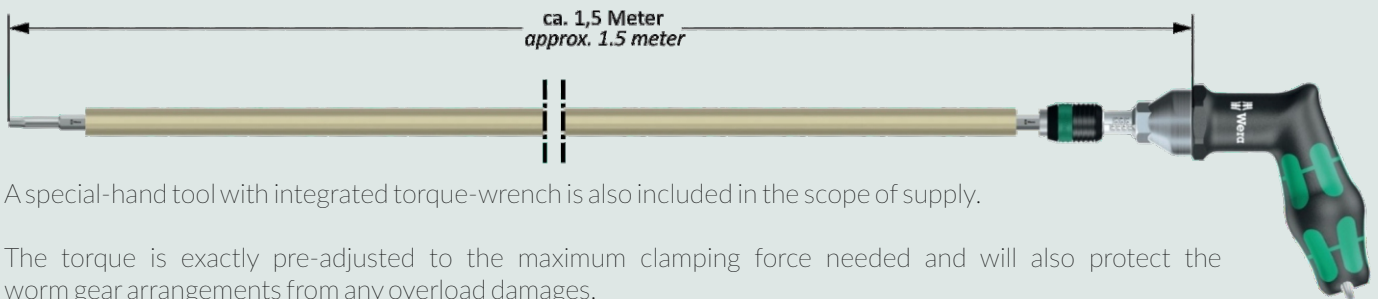
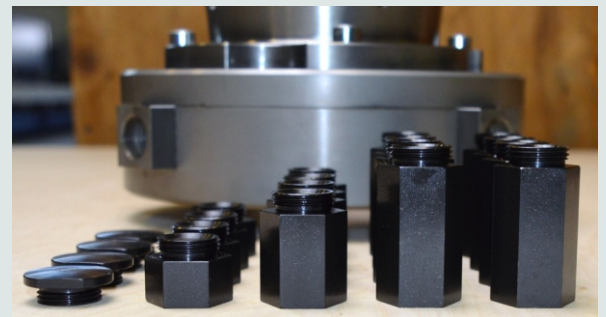

A special-hand tool with integrated torque-wrench is also included in the scope of supply.

The torque is exactly pre-adjusted to the maximum clamping force needed and will also protect the worm gear arrangements from any overload damages.